



WENZHUO

真空机系列

温州市华侨包装机械厂

WENZHOU HUAQIAO PACKING MACHINE FACTORY

地址：浙江省温州市空港新区港富路15号
NO.15 Gangfu Road, Konggang New Area,
Wenzhou, Zhejiang.

电话(TEL) : 0577-88633888 88631988
传真(FAX) : 0577-88628808

外贸部 International Department
电话(TEL) : +86-577-88998813
传真(FAX) : +86-577-88996613
<http://www.huaqiaopm.com>
E-mail: huaqiaopm@huaqiaopm.com

上海工厂
上海市嘉定区黄渡镇春浓路732号
NO.732 Chunnong Road, Huangdu Town
Jiading Area Shanghai
电话(TEL) : 021-69596266 69596268
传真(FAX) : 021-69596267
<http://www.afanlao.com>
E-mail: afanlao@afanlao.com

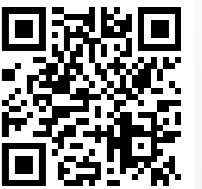

“公司简介”

Introduction

温州市华侨包装机械厂成立于一九八七年,专业生产“捆霸牌”包装机械和食品机械等产品,公司技术力量雄厚、设备齐全、具有开发、研制、生产、销售及售后服务的完整体系。本公司主要产品有:塑料带捆扎机、自动封箱机、超声波自动封口机、真空包装机、墨轮印字封口机、多功能薄膜封口机、盒杯封盖机、打码机、移印机、吸塑包装机、贴体包装机、液体、颗粒、粉剂自动包装机、电磁感应封盖机、自动贴标机和流水线,设计制作等。我厂产品畅销全国二十九个省、市、自治区并出口东南亚、中东、欧美等国家和地区。其中半自动捆包机已连年创中国销量之最。被中国产品质量协会推荐为“质量信得过产品”。企业通过了ISO9001国际质量体系认证,部分产品已通过欧盟的CE认证,并且是美国中央采购中心采购单位,我们始终本着“为客户创造价值”的核心价值观,不断开拓创新,奋发进取,力争为每一位客户提供品质卓越的产品及完美周到的售前售后服务。我们致力于新产品开发、质量的提高及今后服务的完善,“坚持不懈地力求完美”是我们的宗旨,针对国内外市场的需求,我们不断地开发质优价廉的各类包装机械,广泛应用于各行业。“只有客户的成功,才有华侨的发展”。华侨企业竭诚与国内外各界客商携手合作,共同迈向成功!

Wenzhou Huaqiao Packing Machine Factory, the owner of KUNBA brand, established in 1987 is a professional manufacturer specialized in the research, development and production of Vacuum Packing Machine, Sealing Machine, Carton Sealer, Printer Machine, Strapping Machine, Cup Sealer, Shrink Tunnel, Induction Foil Sealer, Liquid/Semi-liquid Filling Machine. We are located in Wenzhou with convenient transportation access. All of our products comply with international quality standards and are greatly appreciated in a variety of different markets throughout the world.

- ◆ Devote to Packing Machine since 1987.
- ◆ 90000 square meters, 150 employees.
- ◆ Over 10 million dollars annual sales, 60% export to worldwide.
- ◆ well-equipped facilities and excellent quality control
- ◆ ISO9001:2008 CE certificate approved.
- ◆ OEM and customized -design service supplied.



“工厂概览”

View of factory

一流的技术设备,一流的生产配置,是现代企业必不可少的硬件,也是制造优质产品的保证。我们公司持续购进先进的生产设备,引进新材料、新工艺,使产品大众化、系列化、品质化。技术专家直接参与技术指导及生产,保证了产品的稳定性和可靠性。员工与日俱增的精品意识和源源不断的工业精品令世界包装业日新月异。我们以客户为导向,以研究和制造客户需要的、满意的产品为己任。我们凭借其技术的优势和先进的生产工艺、产品开发能力,把技术研究水平和生产工艺发挥的淋漓尽致。从而让客户得到真正的认同和赞赏。





台式真空机

Table type vacuum packager



台式真空机 DZ-260/PD

Table type vacuum packager

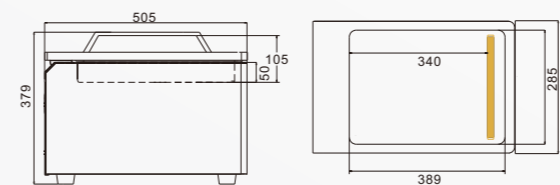

台式真空机 DZ-300/PD

Table type vacuum packager

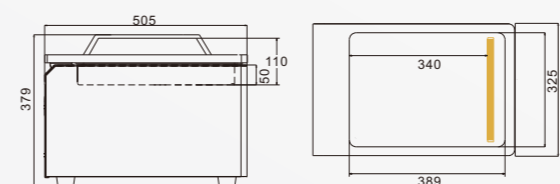

台式真空机储物箱

Stainless steel desk



技术参数 ▼

Technology Parameters ▼

电源电压/Power Supply	AC220V/50Hz 110V/60Hz
电机功率/Power Consumption	0.37Kw
热封功率/Heat Sealing Power	0.15Kw
真空极限压力/Ultimate Vacuum	0.05hPa(mbar)
真空泵抽气速率/Pump Capacity	14.4m ³ /h
热封长度/Sealing Length	250mm
热封宽度/Sealing Width	5mm
真空室深度/Vacuum Chamber Depth	50mm
外包装尺寸/Shipment Dimension	605x435x490mm
净重/毛重/N.W&G.W	37.2Kg/46Kg

技术参数 ▼

Technology Parameters ▼

电源电压/Power Supply	AC220V/50Hz 110V/60Hz
电机功率/Power Consumption	0.37Kw
热封功率/Heat Sealing Power	0.15Kw
真空极限压力/Ultimate Vacuum	0.05hPa(mbar)
真空泵抽气速率/Pump Capacity	14.4m ³ /h
热封长度/Sealing Length	290mm
热封宽度/Sealing Width	5mm
真空室深度/Vacuum Chamber Depth	50mm
外包装尺寸/Shipment Dimension	605x475x490mm
净重/毛重/N.W&G.W	40Kg/49Kg

技术参数 ▼

Technology Parameters ▼

DZ-260/PD箱

箱体尺寸/Machine Size	525x332x514mm
-------------------	---------------

DZ-300/PD箱

箱体尺寸/Machine Size	505x372x514mm
-------------------	---------------



台式真空机

Table type vacuum packager



台式真空机 DZ-400/ZT Table type vacuum packager

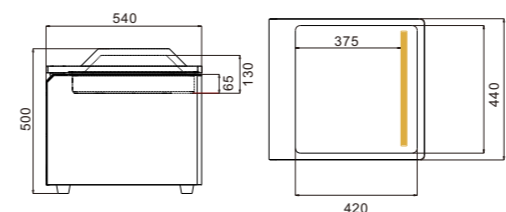

台式真空机 DZ-450/ZT Table type vacuum packager

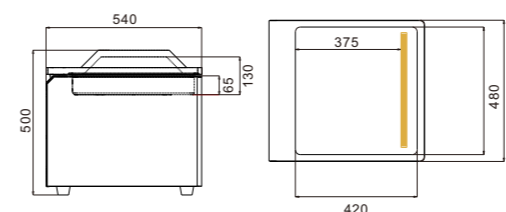

台式真空机 DZ-500/ZT Table type vacuum packager

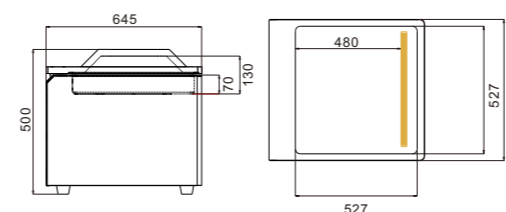

台式真空机 储物箱

Stainless steel desk



技术参数 ▼

Technology Parameters ▼

电源电压/Power Supply	AC220V/50Hz 110V/60Hz
电机功率/Power Consumption	0.9Kw
热封功率/Heat Sealing Power	0.6Kw
真空极限压力/Ultimate Vacuum	0.1hPa(mbar)
真空泵抽气速率/Pump Capacity	20m ³ /h
热封长度/Sealing Length	390mm
热封宽度/Sealing Width	10mm
真空室深度/Vacuum Chamber Depth	65mm
外包装尺寸/Shipment Dimension	660x610x615mm
净重/毛重/N.W&G.W	62.5Kg/77.5Kg

技术参数 ▼

Technology Parameters ▼

电源电压/Power Supply	AC220V/50Hz 110V/60Hz
电机功率/Power Consumption	0.9Kw
热封功率/Heat Sealing Power	0.6Kw
真空极限压力/Ultimate Vacuum	0.1hPa(mbar)
真空泵抽气速率/Pump Capacity	20m ³ /h
热封长度/Sealing Length	440mm
热封宽度/Sealing Width	10mm
真空室深度/Vacuum Chamber Depth	65mm
外包装尺寸/Shipment Dimension	660x660x615mm
净重/毛重/N.W&G.W	70Kg/83Kg

技术参数 ▼

Technology Parameters ▼

电源电压/Power Supply	AC220V/50Hz 110V/60Hz
电机功率/Power Consumption	0.9Kw
热封功率/Heat Sealing Power	0.8Kw
真空极限压力/Ultimate Vacuum	0.1hPa(mbar)
真空泵抽气速率/Pump Capacity	20m ³ /h
热封长度/Sealing Length	490mm
热封宽度/Sealing Width	10mm
真空室深度/Vacuum Chamber Depth	70mm
外包装尺寸/Shipment Dimension	750x700x615mm
净重/毛重/N.W&G.W	77Kg/90Kg

技术参数 ▼

Technology Parameters ▼

DZ-400/ZT箱

箱体尺寸/Machine Size	540x490x420mm
-------------------	---------------



落地式真空机

Vacuum packager

落地式真空机 DZ-400/2E

vacuum packager

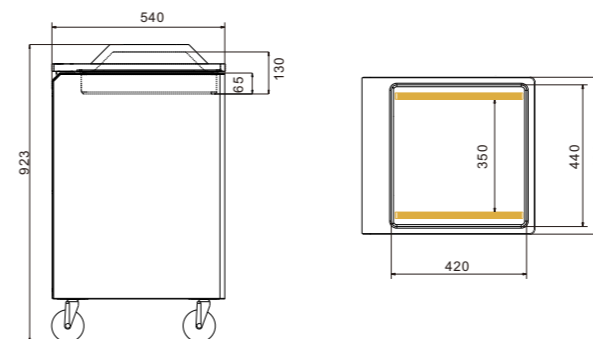

落地式真空机 DZ-500/2E

vacuum packager

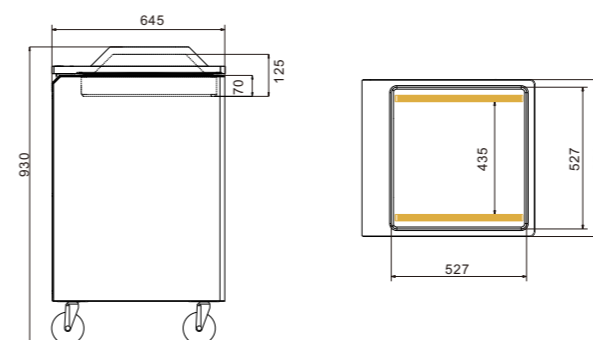

落地式真空机 DZ-600/2E

vacuum packager

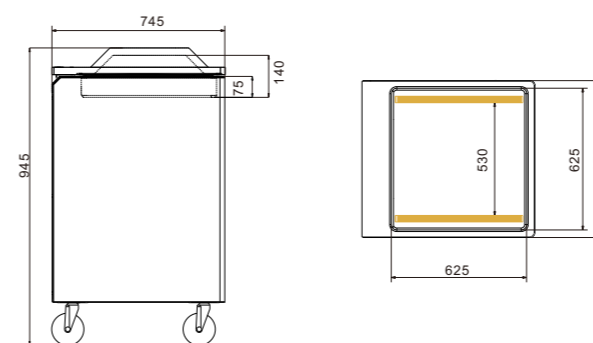

技术参数 ▼

Technology Parameters ▼

电源电压/Power Supply	AC220V/50Hz 110V/60Hz
电机功率/Power Consumption	0.9Kw
热封功率/Heat Sealing Power	0.7Kw
真空极限压力/Ultimate Vacuum	0.1hPa(mbar)
真空泵抽气速率/Pump Capacity	20m ³ /h
热封长度/Sealing Length	390mm
热封宽度/Sealing Width	10mm
真空室深度/Vacuum Chamber Depth	65mm
外包装尺寸/Shipment Dimension	660x610x1070mm
净重/毛重/N.W&G.W	70Kg/87Kg

技术参数 ▼

Technology Parameters ▼

电源电压/Power Supply	AC220V/50Hz 110V/60Hz
电机功率/Power Consumption	0.9Kw
热封功率/Heat Sealing Power	0.9Kw
真空极限压力/Ultimate Vacuum	0.1hPa(mbar)
真空泵抽气速率/Pump Capacity	20m ³ /h
热封长度/Sealing Length	490mm
热封宽度/Sealing Width	10mm
真空室深度/Vacuum Chamber Depth	70mm
外包装尺寸/Shipment Dimension	750x700x1070mm
净重/毛重/N.W&G.W	97Kg/117Kg

技术参数 ▼

Technology Parameters ▼

电源电压/Power Supply	AC380V/50Hz 220V/60Hz
电机功率/Power Consumption	1.5Kw
热封功率/Heat Sealing Power	1.1Kw
真空极限压力/Ultimate Vacuum	0.1hPa(mbar)
真空泵抽气速率/Pump Capacity	40m ³ /h
热封长度/Sealing Length	590mm
热封宽度/Sealing Width	10mm
真空室深度/Vacuum Chamber Depth	75mm
外包装尺寸/Shipment Dimension	850x800x1070mm
净重/毛重/N.W&G.W	151Kg/178Kg



落地式真空机 (加深型 + 不锈钢盖)

Vacuum packager(extra deep type+Stainless steel cover)

落地式真空机 DZ-400/2E vacuum packager

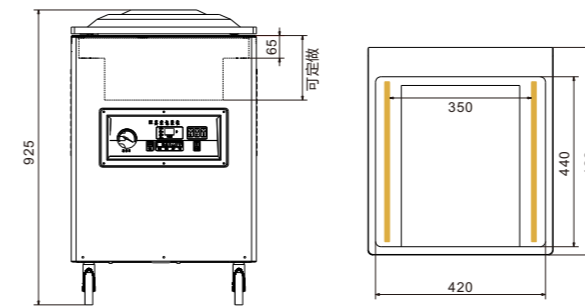

技术参数 ▼

Technology Parameters ▼

电源电压/Power Supply	AC220V/50Hz 110V/60Hz
电机功率/Power Consumption	0.9Kw
热封功率/Heat Sealing Power	0.7Kw
真空极限压力/Ultimate Vacuum	0.1hPa(mbar)
真空泵抽气速率/Pump Capacity	20m ³ /h
热封长度/Sealing Length	390mm
热封宽度/Sealing Width	10mm
真空室深度/Vacuum Chamber Depth	可定做
外包装尺寸/Shipment Dimension	660x610x1070mm
净重/毛重/N.W&G.W	90Kg/107Kg

落地式真空机 DZ-500/2E vacuum packager

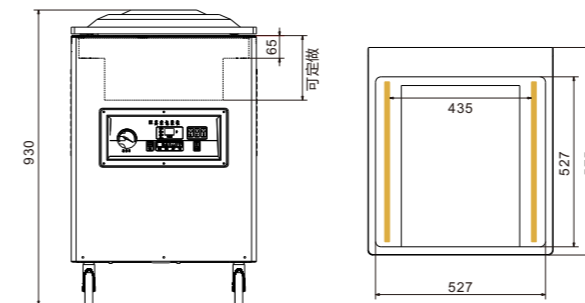

技术参数 ▼

Technology Parameters ▼

电源电压/Power Supply	AC220V/50Hz 110V/60Hz
电机功率/Power Consumption	0.9Kw
热封功率/Heat Sealing Power	0.9Kw
真空极限压力/Ultimate Vacuum	0.1hPa(mbar)
真空泵抽气速率/Pump Capacity	20m ³ /h
热封长度/Sealing Length	490mm
热封宽度/Sealing Width	10mm
真空室深度/Vacuum Chamber Depth	可定做
外包装尺寸/Shipment Dimension	750x700x1070mm
净重/毛重/N.W&G.W	122Kg/144Kg

落地式真空机 DZ-600/2E vacuum packager

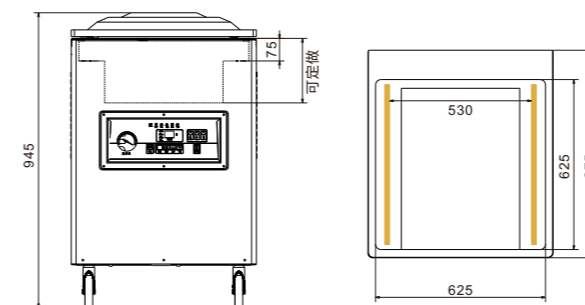

技术参数 ▼

Technology Parameters ▼

电源电压/Power Supply	AC380V/50Hz 220V/60Hz
电机功率/Power Consumption	1.5Kw
热封功率/Heat Sealing Power	1.1Kw
真空极限压力/Ultimate Vacuum	0.1hPa(mbar)
真空泵抽气速率/Pump Capacity	40m ³ /h
热封长度/Sealing Length	590mm
热封宽度/Sealing Width	10mm
真空室深度/Vacuum Chamber Depth	可定做
外包装尺寸/Shipment Dimension	850x800x1070mm
净重/毛重/N.W&G.W	180Kg/208Kg



落地式真空机

Vacuum packager

落地式真空机 DZ-800/2L
vacuum packager

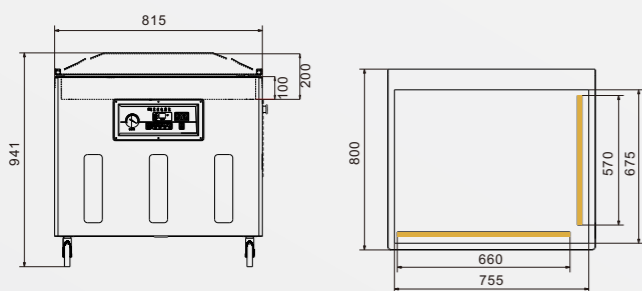

技术参数 ▼
Technology Parameters ▼

电源电压/Power Supply	AC380V/50Hz 220V/60Hz
电机功率/Power Consumption	1.5Kw
热封功率/Heat Sealing Power	1.4Kw
真空极限压力/Ultimate Vacuum	0.1hPa(mbar)
真空泵抽气速率/Pump Capacity	40m ³ /h
热封长度/Sealing Length	650/560mm
热封宽度/Sealing Width	10mm
真空室深度/Vacuum Chamber Depth	100mm
外包装尺寸/Shipment Dimension	890x1035x1100mm
净重/毛重/N.W&G.W	215Kg/260Kg

落地式真空机 DZ-900/2L
vacuum packager

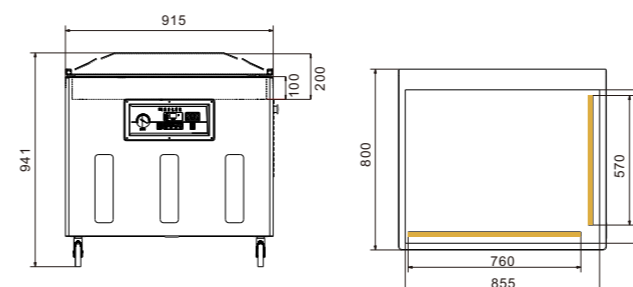

技术参数 ▼
Technology Parameters ▼

电源电压/Power Supply	AC380V/50Hz 220V/60Hz
电机功率/Power Consumption	1.5Kw
热封功率/Heat Sealing Power	1.6Kw
真空极限压力/Ultimate Vacuum	0.1hPa(mbar)
真空泵抽气速率/Pump Capacity	40m ³ /h
热封长度/Sealing Length	750/560mm
热封宽度/Sealing Width	10mm
真空室深度/Vacuum Chamber Depth	100mm
外包装尺寸/Shipment Dimension	890x1135x1100mm
净重/毛重/N.W&G.W	225Kg/270Kg

落地式真空机 DZ-1000/2L
vacuum packager

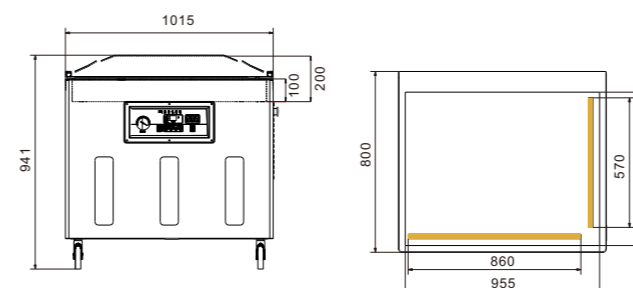

技术参数 ▼
Technology Parameters ▼

电源电压/Power Supply	AC380V/50Hz 220V/60Hz
电机功率/Power Consumption	1.5Kw
热封功率/Heat Sealing Power	1.8Kw
真空极限压力/Ultimate Vacuum	0.1hPa(mbar)
真空泵抽气速率/Pump Capacity	40m ³ /h
热封长度/Sealing Length	850/560mm
热封宽度/Sealing Width	10mm
真空室深度/Vacuum Chamber Depth	100mm
外包装尺寸/Shipment Dimension	890x1235x1100mm
净重/毛重/N.W&G.W	235Kg/280Kg

落地式真空机 DZ-1100/2L
vacuum packager

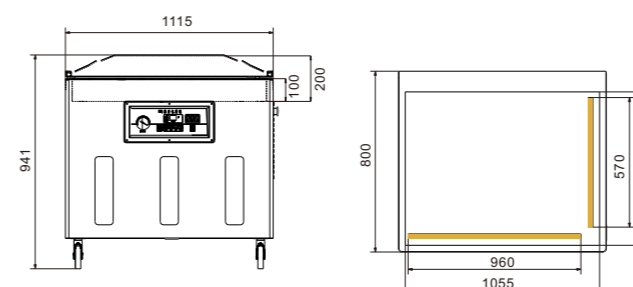

技术参数 ▼
Technology Parameters ▼

电源电压/Power Supply	AC380V/50Hz 220V/60Hz
电机功率/Power Consumption	1.5Kw
热封功率/Heat Sealing Power	2.0Kw
真空极限压力/Ultimate Vacuum	0.1hPa(mbar)
真空泵抽气速率/Pump Capacity	40m ³ /h
热封长度/Sealing Length	950/560mm
热封宽度/Sealing Width	10mm
真空室深度/Vacuum Chamber Depth	100mm
外包装尺寸/Shipment Dimension	890x1335x1100mm
净重/毛重/N.W&G.W	245Kg/290Kg



双室真空机(平板型)

Double chamber vacuum packager (flat type)

双室真空机(平板型) DZ-400/2SB

Double chamber vacuum packager (flat type)

技术参数 ▼

Technology Parameters ▼

电源电压/Power Supply	AC220V/50Hz 110V/60Hz
电机功率/Power Consumption	0.9Kw
热封功率/Heat Sealing Power	0.7Kw
真空极限压力/Ultimate Vacuum	0.1hPa(mbar)
真空泵抽气速率/Pump Capacity	20m ³ /h
热封长度/Sealing Length	390mm
热封宽度/Sealing Width	10mm
外包装尺寸/Shipment Dimension	1090x680x1020mm
净重/毛重/N.W&G.W	131Kg/155Kg

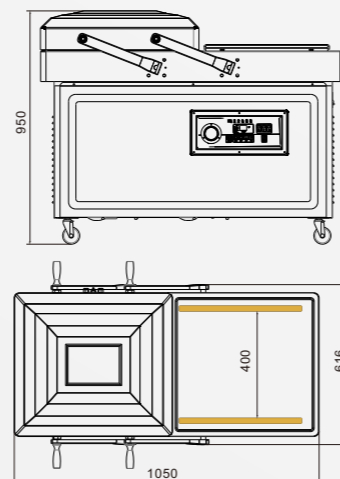

双室真空机(平板型) DZ-500/2SB

Double chamber vacuum packager (flat type)

技术参数 ▼

Technology Parameters ▼

电源电压/Power Supply	AC380V/50Hz 220V/60Hz
电机功率/Power Consumption	0.75Kwx2
热封功率/Heat Sealing Power	0.9Kw
真空极限压力/Ultimate Vacuum	0.1hPa(mbar)
真空泵抽气速率/Pump Capacity	20m ³ /hx2
热封长度/Sealing Length	490mm
热封宽度/Sealing Width	10mm
外包装尺寸/Shipment Dimension	1340x740x1020mm
净重/毛重/N.W&G.W	182Kg/232Kg

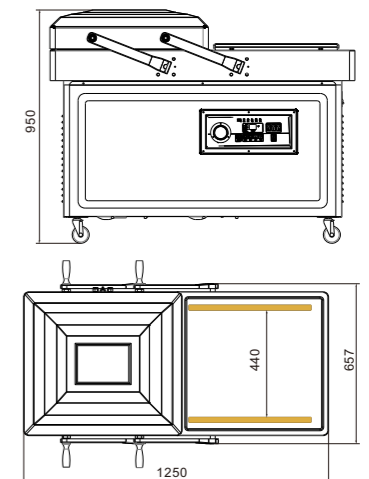

双室真空机(平板型) DZ-600/2SB

Double chamber vacuum packager (flat type)

技术参数 ▼

Technology Parameters ▼

电源电压/Power Supply	AC380V/50Hz 220V/60Hz
电机功率/Power Consumption	1.5Kw
热封功率/Heat Sealing Power	1.1Kw
真空极限压力/Ultimate Vacuum	0.1hPa(mbar)
真空泵抽气速率/Pump Capacity	40m ³ /h
热封长度/Sealing Length	590mm
热封宽度/Sealing Width	10mm
外包装尺寸/Shipment Dimension	1530x740x1020mm
净重/毛重/N.W&G.W	220Kg/272Kg

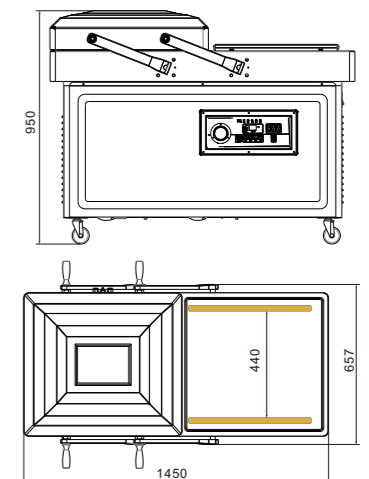

双室真空机(平板型) DZ-700/2SB

Double chamber vacuum packager (flat type)

技术参数 ▼

Technology Parameters ▼

电源电压/Power Supply	AC380V/50Hz 220V/60Hz
电机功率/Power Consumption	1.5Kw
热封功率/Heat Sealing Power	1.3Kw
真空极限压力/Ultimate Vacuum	0.1hPa(mbar)
真空泵抽气速率/Pump Capacity	40m ³ /h
热封长度/Sealing Length	690mm
热封宽度/Sealing Width	10mm
外包装尺寸/Shipment Dimension	1730x815x1045mm
净重/毛重/N.W&G.W	267Kg/330Kg

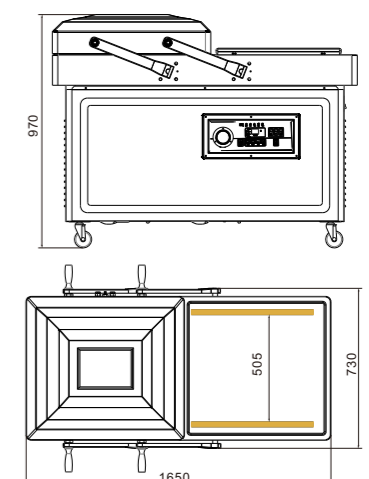



双室真空机(加深型)

Double chamber vacuum packager(deep type)

双室真空机(加深型) DZ-400/2SA

Double chamber vacuum packager (deep type)

技术参数 ▼

Technology Parameters ▼

电源电压/Power Supply	AC380V/50Hz 220V/60Hz
电机功率/Power Consumption	0.9Kw
热封功率/Heat Sealing Power	0.7Kw
真空极限压力/Ultimate Vacuum	0.1hPa(mbar)
真空泵抽气速率/Pump Capacity	20m ³ /h
热封长度/Sealing Length	390mm
热封宽度/Sealing Width	10mm
真空室深度/Vacuum Chamber Depth	40mm
外包装尺寸/Shipment Dimension	1090x680x1030mm
净重/毛重/N.W&G.W	140Kg/160Kg

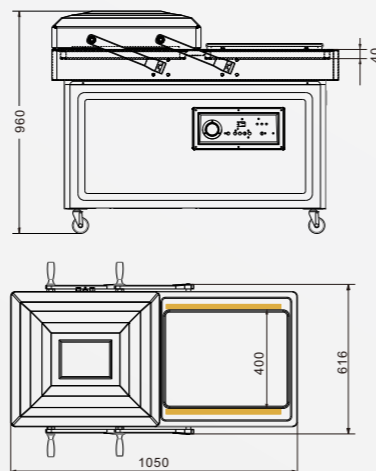

双室真空机(加深型) DZ-500/2SA

Double chamber vacuum packager (deep type)

技术参数 ▼

Technology Parameters ▼

电源电压/Power Supply	AC380V/50Hz 220V/60Hz
电机功率/Power Consumption	0.75Kwx2
热封功率/Heat Sealing Power	0.9Kw
真空极限压力/Ultimate Vacuum	0.1hPa(mbar)
真空泵抽气速率/Pump Capacity	20m ³ /hx2
热封长度/Sealing Length	490mm
热封宽度/Sealing Width	10mm
真空室深度/Vacuum Chamber Depth	40mm
外包装尺寸/Shipment Dimension	1340x740x1030mm
净重/毛重/N.W&G.W	182Kg/232Kg

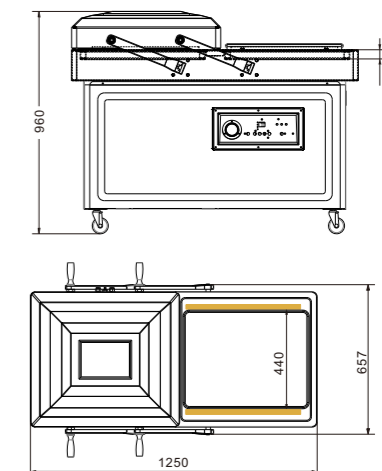

双室真空机(加深型) DZ-600/2SA

Double chamber vacuum packager (deep type)

技术参数 ▼

Technology Parameters ▼

电源电压/Power Supply	AC380V/50Hz 220V/60Hz
电机功率/Power Consumption	1.5Kw
热封功率/Heat Sealing Power	1.1Kw
真空极限压力/Ultimate Vacuum	0.1hPa(mbar)
真空泵抽气速率/Pump Capacity	40m ³ /h
热封长度/Sealing Length	590mm
热封宽度/Sealing Width	10mm
真空室深度/Vacuum Chamber Depth	40mm
外包装尺寸/Shipment Dimension	1530x740x1030mm
净重/毛重/N.W&G.W	220Kg/272Kg

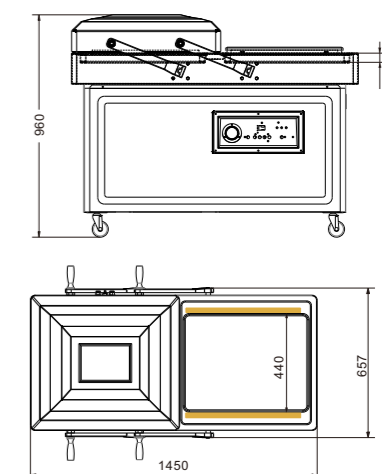

双室真空机(加深型) DZ-700/2SA

Double chamber vacuum packager (deep type)

技术参数 ▼

Technology Parameters ▼

电源电压/Power Supply	AC380V/50Hz 220V/60Hz
电机功率/Power Consumption	1.5Kw
热封功率/Heat Sealing Power	1.3Kw
真空极限压力/Ultimate Vacuum	0.1hPa(mbar)
真空泵抽气速率/Pump Capacity	40m ³ /h
热封长度/Sealing Length	690mm
热封宽度/Sealing Width	10mm
真空室深度/Vacuum Chamber Depth	40mm
外包装尺寸/Shipment Dimension	1730x815x1045mm
净重/毛重/N.W&G.W	267Kg/330Kg

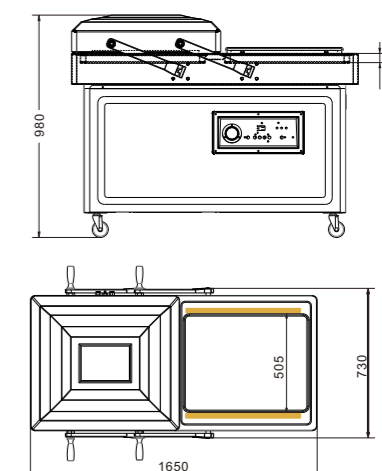



双室真空机(四边封型)

Double chamber vacuum packager

(Multi-sealing Bar)

双室真空机(四边封型) DZ-600/4SB

Double chamber vacuum packager
(with four sealing bars)

技术参数 ▼

Technology Parameters ▼

电源电压/Power Supply	AC380V/50Hz 220V/60Hz
电机功率/Power Consumption	2.2Kw
热封功率/Heat Sealing Power	1.2Kwx2
真空极限压力/Ultimate Vacuum	0.1hPa(mbar)
真空泵抽气速率/Pump Capacity	63m ³ /h
热封长度/Sealing Length	590mm
热封宽度/Sealing Width	10mm
外包装尺寸/Shipment Dimension	1530x980x1040mm
净重/毛重/N.W&G.W	322Kg/378Kg

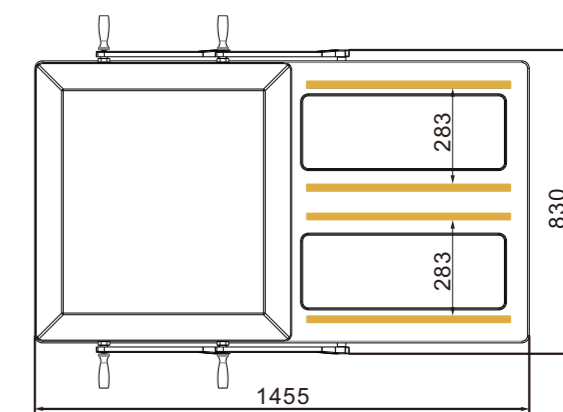
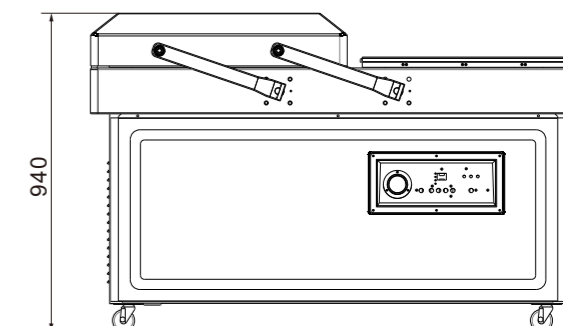



双室真空机(自动翻盖型)

Double chamber vacuum packager(Automatic flip)

双室真空机(自动翻盖型) DZ-600/2SA

Double chamber vacuum packager (Automatic flip)

技术参数 ▼

Technology Parameters ▼

电源电压/Power Supply	AC380V/50Hz 220V/60Hz
电机功率/Power Consumption	3.0Kw
热封功率/Heat Sealing Power	1.1Kw
真空极限压力/Ultimate Vacuum	0.1hPa(mbar)
真空泵抽气速率/Pump Capacity	100m ³ /h
热封长度/Sealing Length	590mm
热封宽度/Sealing Width	10mm
外包装尺寸/Shipment Dimension	1530x1030x1060mm
净重/毛重/N.W&G.W	370Kg/420Kg

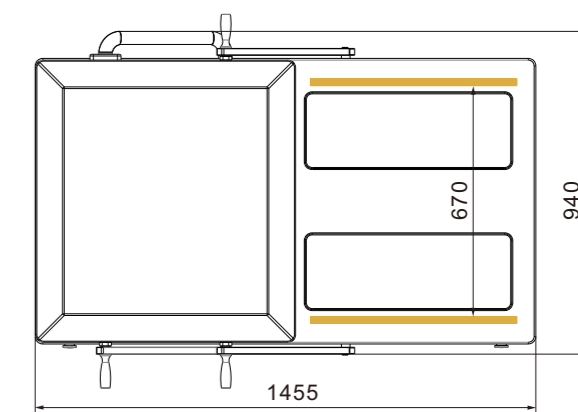
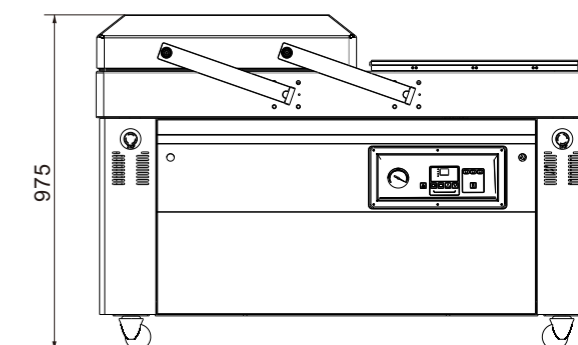

双室真空包装机 DZK-500/S

Double chamber vacuum packager

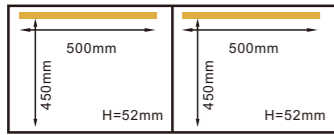

技术参数 ▼

Technology Parameters ▼

电源电压/Power Supply	AC 380/50 220/50 110/60
真空泵电机功率(W)/Motor Power	1800
热封功率/Heat Sealing Power	600
真空室最低绝对压强/Ultimate Vacuum Pressure(KPa)	1
每室热封条数/No,of Seal Bars for Each Chamber	1
真空室尺寸/Chamber Dimensions(L×W×H)(mm)	550×500×180
热封长度/Sealing Length	500
热封宽度/Sealing Width	10
真空泵排气量/Pump Capacity(m ³ /h)	20×2
真空室材质/Material for Vacuum Chamber	不锈钢 Stainless steel
外形尺寸/External Dimensions (L×W×H)(mm)	1690×710×1055
净重/Net weight(kg)	220

性能与说明:

DZK-500/S双室可倾式大米真空包装机,是为物料水平放置容易倾倒的需求而设计的,倾斜度可在80°范围内调节。每室有一条封口线,在真空室下部有托板可托住包装的底部,托板的高低可以调节。标准规格的机型,可包装≤10kg大米及类似的物料。该机较外抽式大米真空包装机抽真空的效果更好,已被广泛应用。

Description:

· DZK-500/S Double-Chamber vacuum Packaging Machine, whose chamber is adjustable within 80°, aiming to place the products more easily. There is a piece of sealing assembly and a support panel at the chamber bottom (height is adjustable). Standard model can pack grains or something similar with weight below 10kg. This model is widely used, for its superior excellence in vacuum percentage, compared to other grain vacuum machine.

多功能真空气调包装机 ZQ-700L

Vacuum gas-tilling packing machine

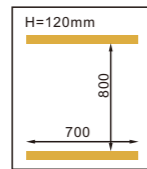

技术参数 ▼

Technology Parameters ▼

电源电压/Power Supply	AC380V/50Hz
电机功率/Power Consumption	1.25Kw
空压机功率/Air Compressor Power	1.1Kw
封口长度/Sealing Length	600mm、700mm、 800mm、1000mm
封口宽度/Sealing Width	8mm、10mm
封口中心到地面尺寸/ Size Form Sealing Centre To Floor	1060mm
真空泵排气量/Pump Capacity	20m ³ /h
外包装尺寸/Shipment Dimension	800×900×1700mm
净重/毛重/Gross Weight	240Kg

性能与说明:

ZQ-700L多功能真空气调包装机,功能齐全,可用于间歇的单一封口包装,也可用于真空包装或真空后充入惰性气体的包装。采用无室双气嘴机构,不受真空大小的限制,应用范围极广。适用于真空度要求极低,充气纯度较高的物品包装;如热封较厚塑料装或复合袋,可采用双加DZQ-700L/S的机型。特殊订货可将封口长度增大至700mm、800mm、1000mm。

Description:

DZQ-700L multi-functional gas-filling packaging machine can be used not only for sealing packages, but also for vacuum packaging or packing of filling inert gas in bag vacuum. It adopts no case and double gas nozzle design and is not limited by vacuum room. It is suitable for the package of requirement of vacuum and good gas-filling pure. If sealing the plastic film and Alplastic compound bag, DZQ-700/S double beating sealer. For special sealing, the length can add to 700, 800, 1000mm

盒式真空气调自动包装机 DZQ-210HL

Double chamber vacuum packager



性能与说明:

本系列真空包装机具有抽真空、封口、印字、冷却一次性完成之功能,适用于食品、药品、水产、化工原料、电子元件等产品的真空包装,可防止产品的氧化霉变、防腐防潮、可保质、保鲜、延长产品的储存期限。

Description:

The series of vacuum packing machine is featured by automatically process of vacuuming, sealing, printing, cooling, which is used in vacuum packaging for the food, pharmaceutical, aquatic, chemical and electronic industries. It can prevent the products from oxidization and moisture, keeping the quality and freshness of the product over a prolonged storage time.

技术参数 ▼

Technology Parameters ▼

型号/Model	DZQ-210HL
电源电压/Power Supply	AC380V/50Hz
总功率/Power Consumption	10Kw
排气量/Exhaustment	120m ³ /h
真空压强/Vacuum Pressure	≥0.5Mpa
冷却水/Cooling Water Pressure	≥0.1Mpa
外包装尺寸/Shipment Dimension	485×880×1860mm
净重/毛重/Gross Weight	1380Kg

连续式真空包装机

Automatic Continuous Vacuum Packaging Machine



电源电压	电机功率	热封功率	热封长度	真空室最低绝对压强	包装速度 (次/分钟)	真空泵排气量	封口宽度	真空室尺寸	热封条数量	外形尺寸	净重
Voltage (V/Hz)	Motor Power (KW)	Sealing Power(KW)	Sealing Length(mm)	Ultimate Vacuum Pressure(KPa)	Capacity (times/min)	Pump Capacity (m ³ /h)	Sealing Width (mm)	Chamber Dimensions (LxWxH)(mm)	NO.of Sealing Bars	External Dimensions (LxWxH)(mm)	Net weight (kg)
AC 380/50 220/60	3	2	1020	1	4-8	100or200	10mm 2x3mm	1080x500x80	2	1580x1770x1100	720

盒式真空气调自动包装机

Automatic Tray Vacuum Gas-flushing Packaging Machine



型号	电源电压	总功率	热封功率	真空室最低绝对压强	包装速度 (次/分钟)	上膜宽度	真空泵排气量	真空室尺寸	外形尺寸	净重
Model	Voltage (V/Hz)	Total Power (KW)	Sealing Power(KW)	Ultimate Vacuum Pressure(KPa)	Capacity (times/min)	Upper Film Width(mm)	Pump Capacity (m ³ /h)	Chamber Dimensions (LxWxH)(mm)	External Dimensions (LxWxH)(mm)	Net weight(kg)
HVT-450A	AC 380/50 220/60	3	2	1	2-6	2-6	63	410x270x60	2200x950x1760	600

低温烹饪机 SV-08

Sous Vide Cooking Bath



技术特点 ▼

Technical Features ▼

型号/Model	SV-08
最高温度/Maximum temperature(°C)	85°C
温度稳定性/Temperature constant(°C)	+/- 0.5°C
温度显示最小值/Display resolution(°C)	0.1°C
内胆容积/Capacity(L)	8L
净重/Net Weight(kgs)	9.8kgs
毛重/Gross Weight(kgs)	11.9kgs
功率/Consume power(W)	1000W
内胆尺寸/Internal dimension(mm)	327X265X150mm
机器尺寸/Outer dimension(mm)	370x305x310mm
电压/Voltage supply	100V-240V 50/60HZ (根据客户不同市场)

低温烹饪机 SV-56

Sous Vide Cooking Bath



技术特点 ▼

Technical Features ▼

型号/Model	SV-56
最高温度/Maximum temperature(°C)	85°C
温度稳定性/Temperature constant(°C)	+/- 0.5°C
温度显示最小值/Display resolution(°C)	0.1°C
内胆容积/Capacity(L)	56L
净重/Net Weight(kgs)	27kgs
毛重/Gross Weight(kgs)	32kgs
功率/Consume power(W)	2400W
内胆尺寸/Internal dimension(mm)	654X530X200mm
机器尺寸/Outer dimension(mm)	694x673x310mm
电压/Voltage supply	100V-240V 50/60HZ (根据客户不同市场)

低温烹饪机 SV-20/2

Sous Vide Cooking Bath



技术特点 ▼

Technical Features ▼

型号/Model	SV-20/2
最高温度/Maximum temperature(°C)	85°C
温度稳定性/Temperature constant(°C)	+/- 0.5°C
温度显示最小值/Display resolution(°C)	0.1°C
内胆容积/Capacity(L)	40L
净重/Net Weight(kgs)	29kgs
毛重/Gross Weight(kgs)	35kgs
功率/Consume power(W)	4000W
内胆尺寸/Internal dimension(mm)	530X327X150 (X2) mm
机器尺寸/Outer dimension(mm)	715x570x310mm
电压/Voltage supply	100V-240V 50/60HZ (根据客户不同市场)

油旋片式真空泵系列

Oil rotary vane vacuum pump



品牌

KUNBA

型号/Model	XD-020	V0040A	V0063A	V0100A	V0160A
抽气速率/Pump Capacity	20m ³ /h	40m ³ /h	63m ³ /h	100m ³ /h	160m ³ /h
极限压力/Ultimate Vacuum	0.1hpa	0.1hpa	0.1hpa	0.1hpa	0.1hpa
电机功率/Power Consumption	0.9kw	1.50kw	2.2kw	3.0kw	4.0kw
重量/Gross Weight	20kg	50kg	60kg	75kg	180kg

油旋片式真空泵系列

Oil rotary vane vacuum pump



品牌

BUSCH 德国原装进口

型号/Model	RA0021C	RA0040F	RA0063F	RA0100F	RA0160D
抽气速率/Pump Capacity	20m ³ /h	40m ³ /h	63m ³ /h	100m ³ /h	160m ³ /h
极限压力/Ultimate Vacuum	1/20hpa	0.1hpa	0.1hpa	0.1hpa	0.1hpa
电机功率/Power Consumption	0.75kw	1.10kw	1.5kw	2.2kw	4.0kw
重量/Gross Weight	20kg	40kg	60kg	100kg	160kg

外接泵系列

External vacuum pump



品牌

KUNBA

型号/Model	2X-15	2X-30A	2X-70A
抽气速率/Pump Capacity	54m ³ /h	108m ³ /h	252m ³ /h
极限压力/Ultimate Vacuum	0.1hpa	0.1hpa	0.1hpa
电机功率/Power Consumption	2.2kw	3.0kw	5.5kw
重量/Gross Weight	190kg	236kg	338kg

备注

**坚持不懈
力求完美**

CONSTANTLY STRIVE
TO PERFECT

只有客户的成功、才有华侨的发展

本厂有权保留对机器技术参数的修改 不另行通知

(Huaqiao reserve the right to change technical parameters without previous advice)